

COLLEZIONE



Rotondo

DIAMETRO INTERNO
INTERNAL DIAMETER

Ø**120**cm

LEGNA / WOOD COD. F12RW

INGOMBRO ESTERNO 160x165 CM
EXTERNAL DIMENSION 160x165 CM



orientamento...versatile

Il design circolare della struttura permette di calibrare perfettamente l'angolazione della bocca del forno senza sacrificare spazio prezioso. Un orientamento ideale consente di non accavallare le postazioni di lavoro evitando inutili intoppi e rallentamenti. La bocca è incorniciata comunque da un segmento rettangolare per facilitare un'eventuale incasso nella parete.

versatile trait

Round design allows to regulate the angle of the oven mouth to make the best use of the available space. Accurate orientation consents to avoid workstations' overlap preventing problems and delays. Mouth is framed by a rectangular segment to facilitate recess in the wall.

STRUTTURA STRUCTURE

Cupola e piano di cottura
costruiti a mano in
mattoni refrattari



*Vault and cooking
deck hand-made with refractory
firebricks*

TIPI DI ALIMENTAZIONE POWER SUPPLY

Legna
Wood



CAPACITÀ PRODUTTIVA TEORICA THEORETICAL PRODUCTION CAPACITY

Piccole e medie produzioni - Small & medium production

Numero pizze* per infornata
Number of pizzas*

6



*pizze da Ø 30cm
*30cm Ø pizzas

Produzione media oraria
Average hourly production

144/h



infornata da 2,30min a pieno carico
2.30min batches at full load

ASSEMBLAGGIO BUILDING

- Montato sul posto
- Pre assemblato in fabbrica

- On site building
- Shipped already built



PIANO DI COTTURA COOKING DECK

Piano di cottura fisso

Stationary cooking deck



BOCCA FORNO OPENING

Apertura bocca standard
Standard door opening



larghezza width 52 cm
altezza height 26 cm

Apertura bocca con baffi
Enlarged door opening



larghezza width 65 cm
altezza height 26 cm

ALLACCIO CANNA FUMARIA CHIMNEY CONNECTION

Femmina diametro interno
Female internal diameter

200mm



PESO WEIGHT

2300



CERTIFICAZIONI - CERTIFICATES



I prodotti sono realizzati artigianalmente
Le misure possono subire variazioni
Products are handmade - Measures
may change



ceky
FORNI DAL 1935

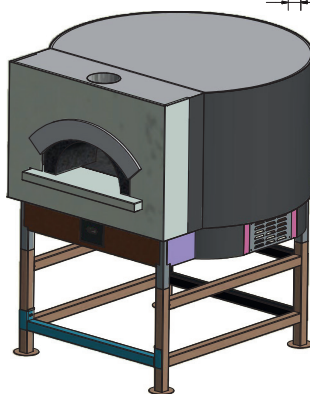
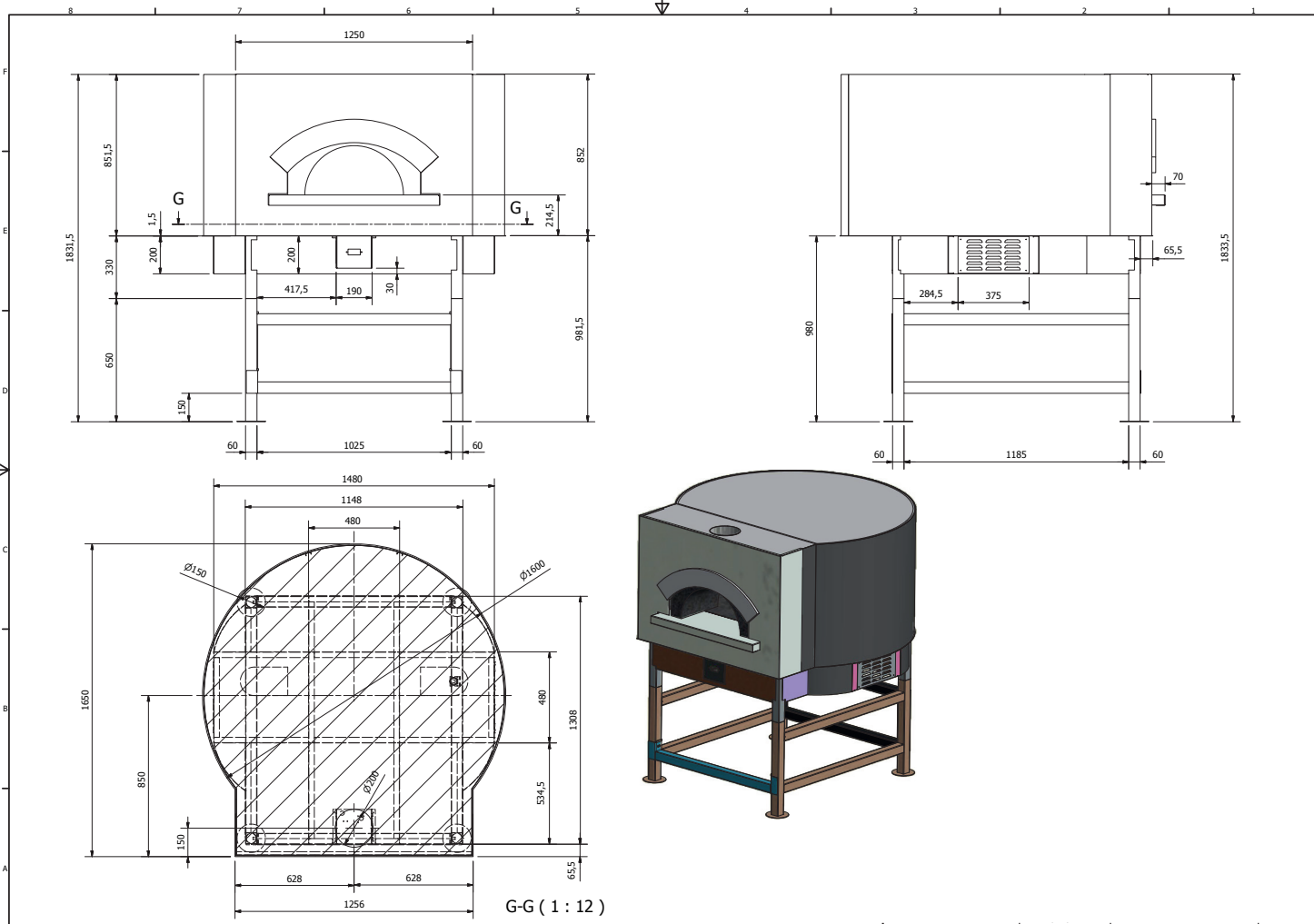

ABBATTITORE DI FULGINE - OPZIONALE WATER FILTER - OPTIONAL

L'abbattitore di fuliggine ha la funzione di eliminare particolato carbonioso (soot) ed impurità di vario genere dai fumi di combustione, e trova impiego laddove sia necessario depurare da scorie non tossiche il fumo di scarico prima di immetterli nell'ambiente. L'abbattitore possiede un sistema di doppio lavaggio: l'acqua di lavaggio può essere smaltita nella rete fognaria. Dalla macchina esce aria satura di vapore, ad una temperatura di circa 50 gradi, priva di particolato carbonioso ed impurità sospese (95% di abbattimento). Gli odori vengono abbattuti del 60-70%.

Our water filter is used to remove soot and other impurities from the exhaust fumes created by wood's combustion inside the oven. It can be installed whenever it is necessary to remove non toxic waste from the fumes before releasing them in the air through the flue.

Our filter use water to wash fumes in a 2-step process. The final product releasing from the machine will be steam filled air, at a 50°C temperature, cleaned by most (95%) of its original wastes. Smell will also be reduced by 60-70%

Ingombro esterno 940 x 670 650 mm
External dimensions

Peso (vuoto e operativo) 50Kg - 125Kg
Weight (empty and operating)

Allaccio canna fumaria 250mm
Chimney Connections

Alimentazione nominale 220÷240 VAC @ 50/60 Hz 3A
Nominal power supply

IMBALLO PACKING

Bancale HT ISPM15 scatolato in cartone con coperchio ISPM15
HT ISPM15 pallet with cardboard box and ISPM15 cover

1800x1800mm
H 1600mm



DECORAZIONI DISPONIBILI AVAILABLE DECORATIONS

Mattoni - mattonelle - palladiane - mosaici
Bricks - tiles - marble - mosaic



ULTERIORI PERSONALIZZAZIONI FURTHER CUSTOMIZATION

Su richiesta
Upon request

