

IL ROTANTE Tondo



DIAMETRO INTERNO
INTERNAL DIAMETER

Ø150cm

Legna / Backup elettrico / Wood / electrical backup COD. FR15SW

INGOMBRO ESTERNO 195x235 CM
EXTERNAL DIMENSION 195x235CM



La cottura più facile ed omogenea

Grazie alla rotazione del piano cottura, i forni rotanti hanno rivoluzionato il mestiere del pizzaiolo e non solo.

Grazie a questa nuova tecnologia la cottura della pizza viene gestita interamente dal forno, che con il suo movimento rotatorio distribuisce il calore uniformemente in ogni punto, eliminando di fatto il lato radiante.

Questo permette di non dover seguire la cottura girando le pizze e quindi dedicare il lavoro principalmente alle fasi di stesura e condimento, garantendo maggiori volumi di infornate e minori tempi di attesa.

Most efficient and easy baking

Maximum space rationality: four perpendicular walls allow the structure to fit perfectly in the layout of your restaurant. External design is customizable thanks to a wide choice of coverings. Solutions with high visual impact make this model an ideal piece of furniture for your restaurant. Round cooking chamber guarantees the most favourable heat diffusion and circulation.

STRUTTURA STRUCTURE

Cupola e piano di cottura
costruiti a mano in
mattoni refrattari



*Vault and cooking
deck hand-made with refractory
firebricks*

TIPI DI ALIMENTAZIONE POWER SUPPLY

Legna / Backup
elettrico



*Wood / electrical
backup*

CAPACITÀ PRODUTTIVA TEORICA THEORETICAL PRODUCTION CAPACITY

Grandi produzioni - Big production

Numero pizze* per infornata
Number of pizzas*

13



*pizze da Ø 30cm
*30cm Ø pizzas

Produzione media oraria
Average hourly production

240/h



infornata da 2,30min a pieno carico
2.30min batches at full load

ASSEMBLAGGIO BUILDING

- Montato sul posto
- Pre assemblato in fabbrica

- On site building
- Shipped already built



PIANO DI COTTURA COOKING DECK

Piano di cottura rotante

Rotating cooking deck



BOCCA FORNO OPENING

Apertura bocca standard
Standard door opening



larghezza *width* 52 cm
altezza *height* 26 cm

PANNELLO DI CONTROLLO CONTROL PANEL

Controllo touch screen
con esclusivo telecomando
per controllo a distanza



*Touch screen and remote for
an easy and fast control*

ALLACCIO CANNA FUMARIA CHIMNEY CONNECTION

Femmina diametro interno
Female internal diameter

200mm



PESO WEIGHT

3000



CARATTERISTICHE MAIN FEATURES

Programmi di cottura
personalizzabili
Customizable baking
programs



CERTIFICAZIONI CERTIFICATES



I prodotti sono realizzati artigianalmente
Le misure possono subire variazioni
Products are handmade - Measures
may change



ceky
FORNI DAL 1935

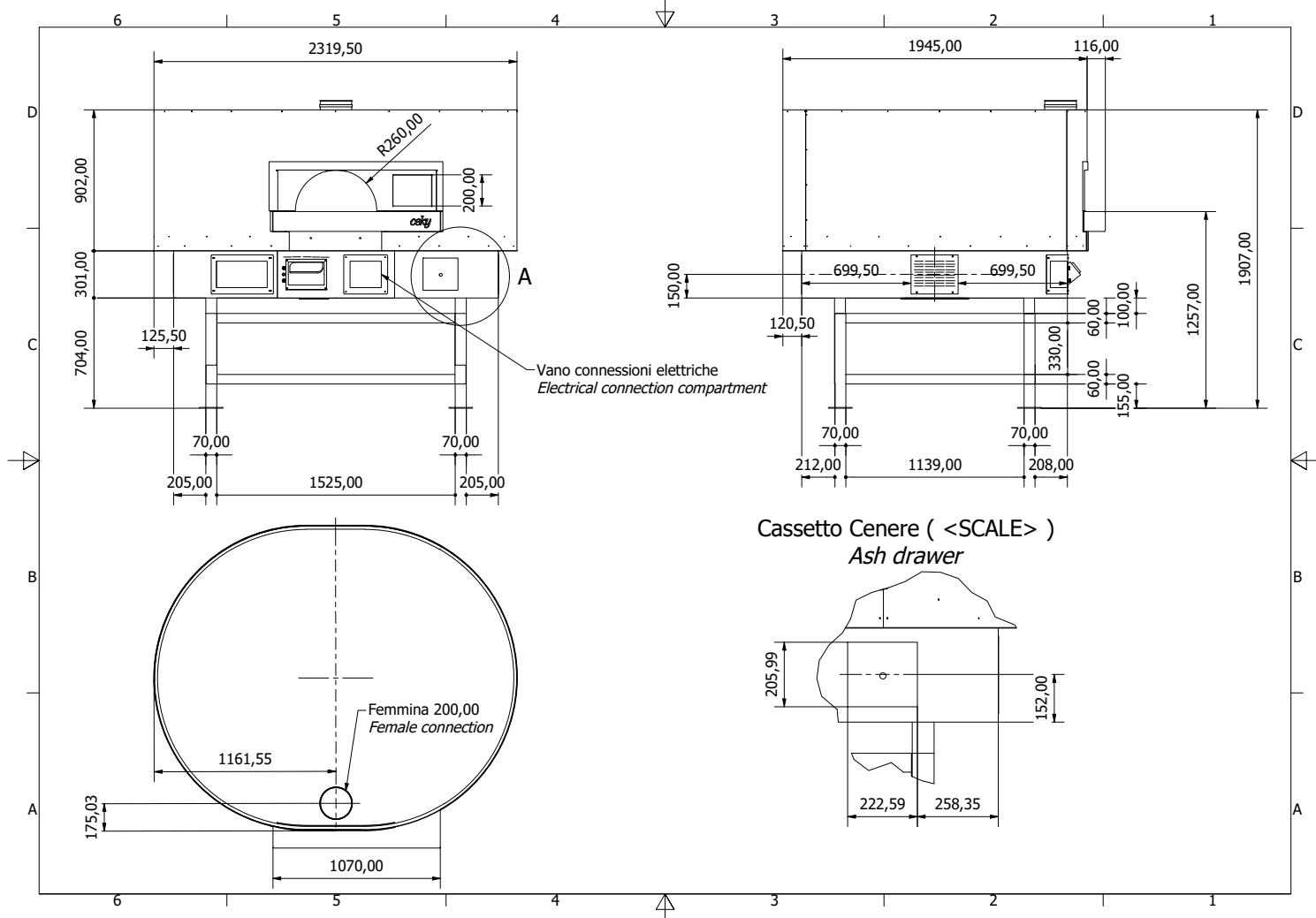

ABBATTITORE DI FULIGGINE - OPZIONALE WATER FILTER - OPTIONAL

L'abbattitore di fuliggine ha la funzione di eliminare particolato carbonioso (soot) ed impurità di vario genere dai fumi di combustione, e trova impiego laddove sia necessario depurare da scorie non tossiche il fumo di scarico prima di immetterli nell'ambiente. L'abbattitore possiede un sistema di doppio lavaggio: l'acqua di lavaggio può essere smaltita nella rete fognaria. Dalla macchina esce aria saturata di vapore, ad una temperatura di circa 50 gradi, priva di particolato carbonioso ed impurità sospese (95% di abbattimento). Gli odori vengono abbattuti del 60-70%.

Our water filter is used to remove soot and other impurities from the exhaust fumes created by wood's combustion inside the oven. It can be installed whenever it is necessary to remove non toxic waste from the fumes before releasing them in the air through the flue.

Our filter use water to wash fumes in a 2-step process. The final product releasing from the machine will be steam filled air, at a 50°C temperature, cleaned by most (95%) of its original wastes. Smell will also be reduced by 60-70%

Ingombro esterno 940 x 670 650 mm
External dimensions

Peso (vuoto e operativo) 50Kg - 125Kg
Weight (empty and operating)

Allaccio canna fumaria 250mm
Chimney Connections

Alimentazione nominale 220÷240 VAC @ 50/60 Hz 3A
Nominal power supply

IMBALLO PACKING

Bancale HT ISPM15 scatolato in cartone con coperchio ISPM15
HT ISPM15 pallet with cardboard box and ISPM15 cover

2000x4000mm
H 1600mm



DECORAZIONI DISPONIBILI AVAILABLE DECORATIONS

Mattoni - mattonelle - palladiane - mosaici
Bricks - tiles - marble - mosaic



ULTERIORI PERSONALIZZAZIONI FURTHER CUSTOMIZATION

Su richiesta
Upon request

