

# IL ROTANTE Tondo



**DIAMETRO INTERNO**  
INTERNAL DIAMETER

**Ø120cm**

**Legna / Backup elettrico / Wood / electrical backup COD. FR12SW**

**INGOMBRO ESTERNO 165x205 CM**  
EXTERNAL DIMENSION 165x205CM



## La cottura più facile ed omogenea

Grazie alla rotazione del piano cottura, i forni rotanti hanno rivoluzionato il mestiere del pizzaiolo e non solo.

Grazie a questa nuova tecnologia la cottura della pizza viene gestita interamente dal forno, che con il suo movimento rotatorio distribuisce il calore uniformemente in ogni punto, eliminando di fatto il lato radiante.

Questo permette di non dover seguire la cottura girando le pizze e quindi dedicare il lavoro principalmente alle fasi di stesura e condimento, garantendo maggiori volumi di infornate e minori tempi di attesa.

## Most efficient and easy baking

Maximum space rationality: four perpendicular walls allow the structure to fit perfectly in the layout of your restaurant. External design is customizable thanks to a wide choice of coverings. Solutions with high visual impact make this model an ideal piece of furniture for your restaurant. Round cooking chamber guarantees the most favourable heat diffusion and circulation.

### STRUTTURA STRUCTURE

Cupola e piano di cottura  
costruiti a mano in  
mattoni refrattari



*Vault and cooking  
deck hand-made with refractory  
firebricks*

### TIPI DI ALIMENTAZIONE POWER SUPPLY

Legna / Backup  
elettrico



*Wood / electrical  
backup*

### CAPACITÀ PRODUTTIVA TEORICA THEORETICAL PRODUCTION CAPACITY

**Piccole e medie produzioni - Small & medium production**

Numero pizze\* per infornata  
Number of pizzas\*

**7**



\*pizze da Ø 30cm  
\*30cm Ø pizzas

Produzione media oraria  
Average hourly production

**134/h**



infornata da 2.30min a pieno carico  
2.30min batches at full load

### ASSEMBLAGGIO BUILDING

- Montato sul posto
- Pre assemblato in fabbrica

- On site building
- Shipped already built



### PIANO DI COTTURA COOKING DECK

Piano di cottura rotante

*Rotating cooking deck*



### BOCCA FORNO OPENING

Apertura bocca standard  
Standard door opening



larghezza *width* 52 cm  
altezza *height* 26 cm

### PANNELLO DI CONTROLLO CONTROL PANEL

Controllo touch screen  
con esclusivo telecomando  
per controllo a distanza



*Touch screen and remote for  
an easy and fast control*

### ALLACCIO CANNA FUMARIA CHIMNEY CONNECTION

Femmina diametro interno  
Female internal diameter

**200mm**



### PESO WEIGHT

**2600**



### CARATTERISTICHE MAIN FEATURES

Programmi di cottura  
personalizzabili  
Customizable baking  
programs



### CERTIFICAZIONI CERTIFICATES



I prodotti sono realizzati artigianalmente  
Le misure possono subire variazioni  
Products are handmade - Measures  
may change



**ceky**  
FORNI DAL 1935

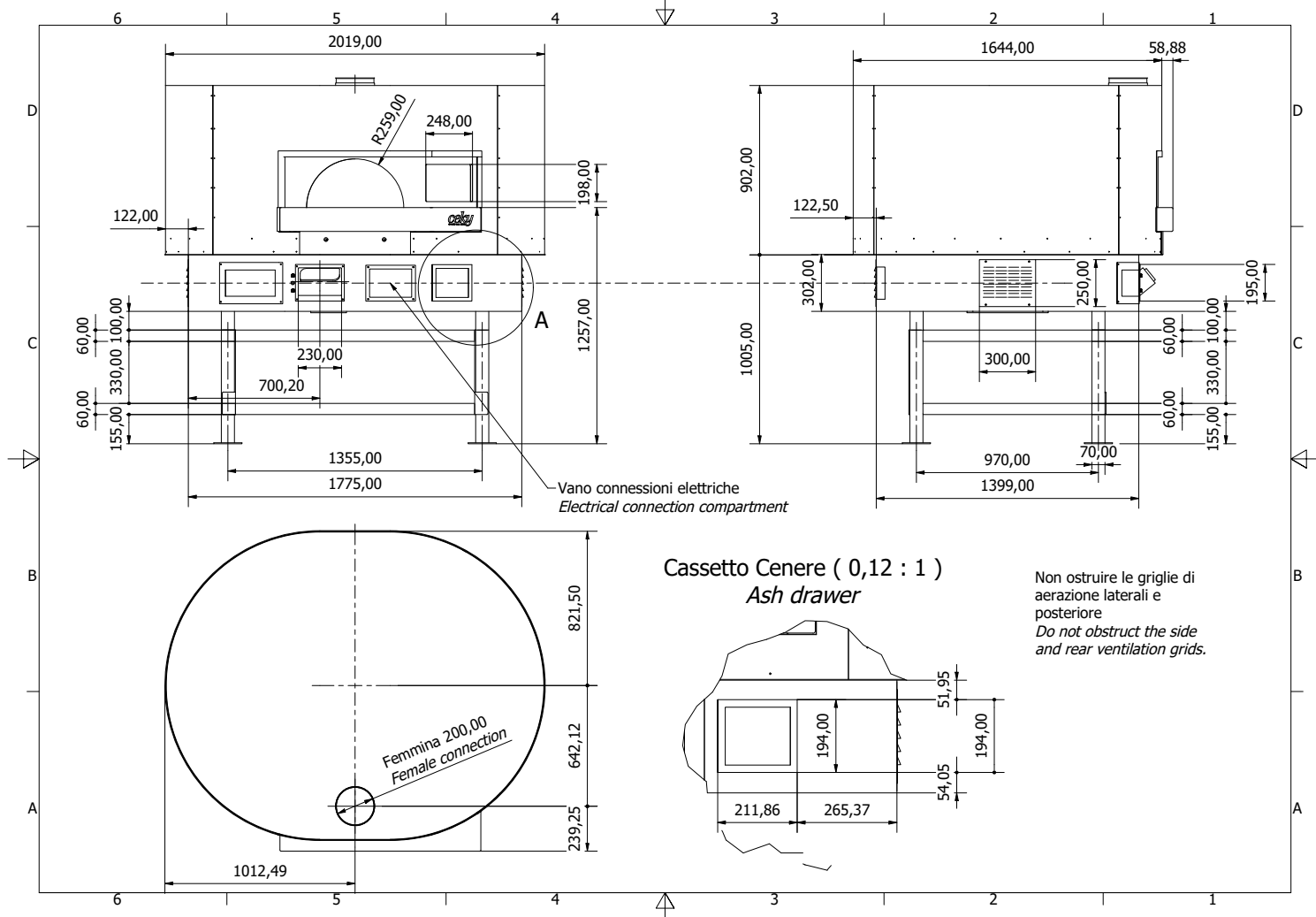

### ABBATTITORE DI FULIGGINE - OPZIONALE WATER FILTER - OPTIONAL

L'abbattitore di fuliggine ha la funzione di eliminare particolato carbonioso (soot) ed impurità di vario genere dai fumi di combustione, e trova impiego laddove sia necessario depurare da scorie non tossiche il fumo di scarico prima di immetterli nell'ambiente. L'abbattitore possiede un sistema di doppio lavaggio: l'acqua di lavaggio può essere smaltita nella rete fognaria. Dalla macchina esce aria satura di vapore, ad una temperatura di circa 50 gradi, priva di particolato carbonioso ed impurità sospese (95% di abbattimento). Gli odori vengono abbattuti del 60-70%.

*Our water filter is used to remove soot and other impurities from the exhaust fumes created by wood's combustion inside the oven. It can be installed whenever it is necessary to remove non toxic waste from the fumes before releasing them in the air through the flue.*

*Our filter use water to wash fumes in a 2-step process. The final product releasing from the machine will be steam filled air, at a 50°C temperature, cleaned by most (95%) of its original wastes. Smell will also be reduced by 60-70%*

Ingombro esterno 940 x 670 650 mm  
*External dimensions*

Peso (vuoto e operativo) 50Kg - 125Kg  
*Weight (empty and operating)*

Allaccio canna fumaria 250mm  
*Chimney Connections*

Alimentazione nominale 220÷240 VAC @ 50/60 Hz 3A  
*Nominal power supply*

### IMBALLO PACKING

Bancale HT ISPM15 scatolato in cartone con coperchio ISPM15  
*HT ISPM15 pallet with cardboard box and ISPM15 cover*

**2000x2100mm**  
**H 1600mm**



### DECORAZIONI DISPONIBILI AVAILABLE DECORATIONS

Mattoni - mattonelle - palladiane - mosaici  
*Bricks - tiles - marble - mosaics*



### ULTERIORI PERSONALIZZAZIONI FURTHER CUSTOMIZATION

Su richiesta  
*Upon request*

